

Sauna™ Quick Tour #1: Heat Sinks, Duty Cycles and Stackup Models

About Sauna Quick Tours

The Sauna Quick Tours let you preview the features provided by the Sauna thermal modeling program. You will create actual models, just like an experienced Sauna user. The documentation explains all modeling steps, so no background with Sauna is required. However, as the name implies, the Sauna Quick Tours are not detailed introductions to the software. Many important topics are skipped over or discussed briefly. To become a skilled user, you need to work the tutorial exercises found in the Sauna User Manuals. Many of these exercise are also available to prospective users on the thermalsoftware.com website.

A basic heat sink model

You will model the geometry shown in Figure 1. *Before beginning the exercise, make sure that the error beep on your computer is turned on (not muted).*

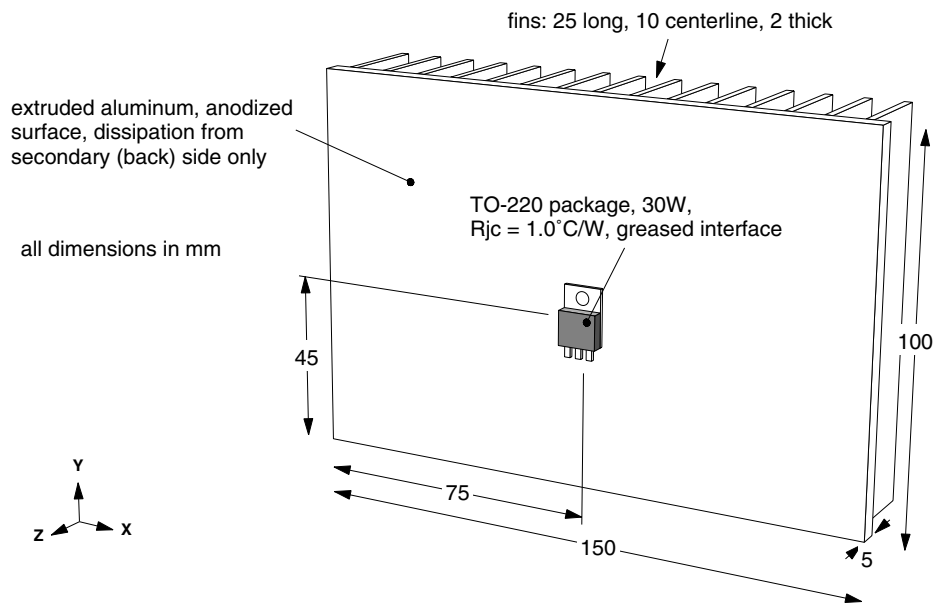

Figure 1: Basic heat sink model

Begin by creating a planar plate assembly:

<F12 Root Menu> → Model → Assembly → Planar Plate → "Heat Sink" (do not type the quotes)
→ Rectangle → Vertical XY → "150,100,5" (do not type the quotes) → (0,0,0)
→ Aluminum → Extruded → Anodized

The planar plate will be created. You will see an array of nodes and resistor inside thick dashed lines. The dashed lines represent the boundaries of the assembly. (Planar plate assemblies have a single plane of nodes and resistors, as opposed to bars and tubes, which can have multiple node/resistor planes.)

Before adding fins, you will switch to a perspective view. For commonly used commands, there are a series of buttons at the lower-left of the Sauna window. The right button in the top row is for switching to a perspective view. Change the view with:

click 

Add fins on the back (secondary side) of the plate:

**<F12 Root Menu> → Edit → Assembly → Plt/Bar Prop → New Fins
→ "25,10,2" (do not type the quotes) → Secondary → Select 1
→ click on edge of plate (dashed line) → USE**

Additional dashed lines will be drawn to show the boundaries of the fins. If you want to see each individual fin, switch to shade mode:

click 

The model will be as shown in Figure 2:

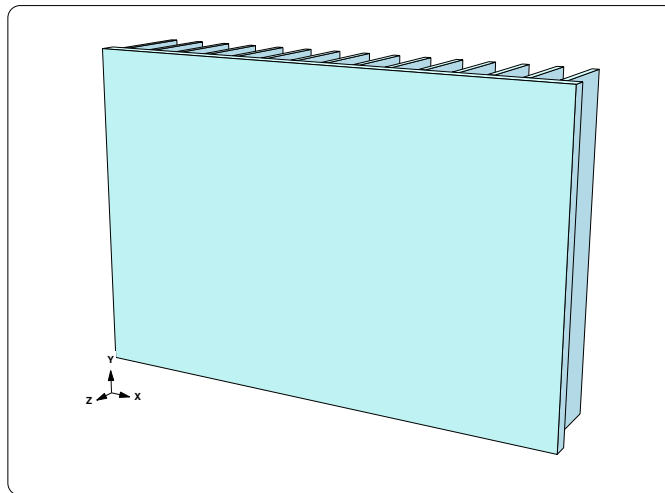

Figure 2: Plate with fins in shade mode

Turn off shade mode, then add the footprint heat source:

click 

**<F12 Root Menu> → Model → Heat Input → Basic Source → "30" → "S1" → TO-220 → Typical
→ Standard → Greased → Plate/Board → One → click edge of plate → Coords/Trap → "75,45"**

A basic heat source will be created. With a basic heat source, it is assumed that all of the heat leaves the package through the base (slug) of the component. The other type of heat source, enhanced, allows for heat transfer through the base, leads and top. Enhanced heat sources are primarily used with circuit boards, as you will see in *Sauna Quick Tour #2: Circuit Board Modeling*.

If you look at the screen, you will that the heat source is connected to the plate with just one case-to-sink resistor. For best accuracy, you should have at least 4 case-to-sink resistors. Sauna has the align command, to quickly resize the plate mesh to match the size and location of the heat source. Align the mesh with:

**<F12 Root Menu> → Edit → Assembly → Remesh/Align → Align → Heat Source
→ 4 Node Conn → click on red heat source node → All In Wind → USE**

The node and resistor mesh will be recreated, and the heat source will be connected with 4 case-to-sink resistors. (Please note: if you make a mistake, use <F12 Root Menu> → Edit → Undo and try again.)

Adding float resistors and a fixed node

At this point, you have defined the heat sink and heat input. However, the current model is invalid. No heat flow path has been established between the heat sink and the ambient temperature environment. A "fixed temperature" node is required to represent the room environment. The name "fixed temperature" comes from the fact that ambient nodes have temperatures which remain fixed throughout the temperature calculation. You also need "float" resistors to represent the convection and radiation. These are called "float resistors" because the resistance values are adjusted according to the ΔT and convection conditions.

Create the fixed node and float resistors:

<F12 Root Menu> → Model → Amb + Float → Isoldt->Fix → "Room Amb"
→ Enter Later → Secondary → All In Wind → USE

The fixed node and float resistors will be created. To better see the new nodes and resistors, switch to a right view:

click

The screen will be as shown in Figure 3:

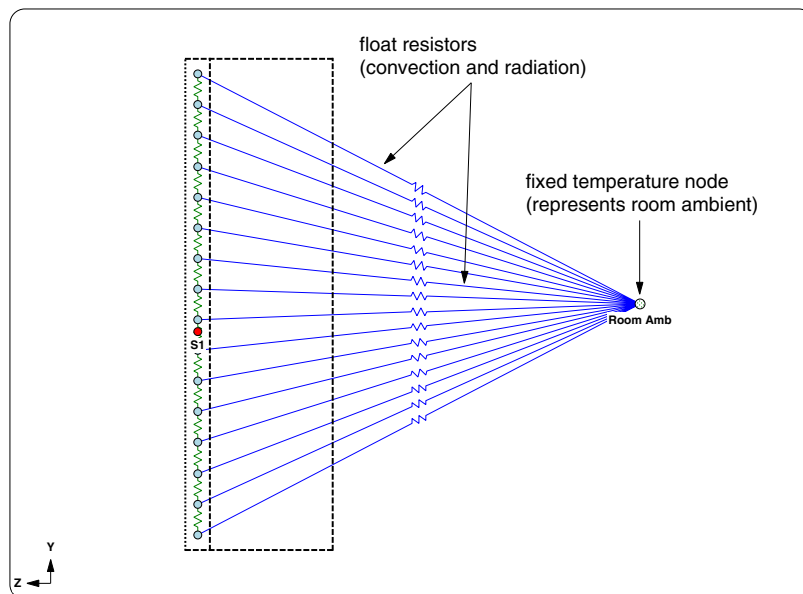

Figure 3: Fixed node and float resistors

Now that the heat flow path to ambient has been created, you can reduce screen clutter by making these nodes and resistors invisible. There's a button for this:

click

Return to a front view:

click

In a moment, you will calculate temperatures. However, before this, it's worthwhile to see a report for the finned plate:

<F7 Info> → Trap → Any Assy → *click edge of plate*

A comprehensive listing of the plate characteristics will be displayed. If you advance to the second page, you will see details on the convection and radiation parameters. The Info reports are an important tool for verifying that the model was created correctly.

After clearing the report from the screen, calculate temperatures with natural cooling:

<F12 Root Menu> → Analyze → Calc Temps → Steady → Natural → "25"

The temperature calculation will only take a second or two. When complete, you will see two temperatures for the heat source. The upper temperature, 137.09°C, is the junction temperature. The lower temperature, 107.09°C, is the case temperature ($T_{\text{junct}} = T_{\text{case}} + q \cdot R_{\text{junct-to-case}}$).

It's also easy to obtain temperatures for forced air cooling. Calculate temperatures at an air velocity of 500 ft/min:

Steady → Forced Air → Feet/Minute → "500" → "25"

You should obtain $T_{\text{junct}} = 108.25^\circ\text{C}$. It's also useful to see the temperature contours:

click 

Before continuing to the next section, turn off the contours:

click 

Duty cycle transient

If you are not interested in duty cycle transient, you can skip ahead to the next section, "Creating a chip stackup".

Up until now, you have been performing "steady state" temperature calculations. For a steady state analysis, it is assumed that the unit has been turned on for sufficient time to achieve stable, unchanging temperatures. Besides steady state analysis, thermal simulation programs also typically provide "simple transient". In simple transient analysis, the unit starts at room temperature and gradually rises to the final steady state temperatures. The shape of the time-temperature curve depends on the mass of the unit and the cooling characteristics.

Sauna does much more than just steady state and simple transient analysis. Sauna provides both "duty cycle" (power changes with time) and "power shutback/control" (power changes as a function of temperature). In this section you will work a square wave duty cycle problem.

To define the square wave problem, you will create a control element. Create a control element with:

<F12 Root Menu> → Model → Control Elem → Create → With Menus → Time Base → Q vs Time → "Sq1" → Minutes → Square Wave → "5" → "1,1" → "1,0" → 4 (*the default*) → Fixed Node

At the bottom of the screen, Sauna will indicate that "Control element "Sq1" successfully created".

Obtain a plot of the newly created control element:

**<F7 Info> → Control Elem → Graph → Time Base → Show Ramp → Minutes
→ All → Full Graph → Screen**

You will see this graph on the screen:

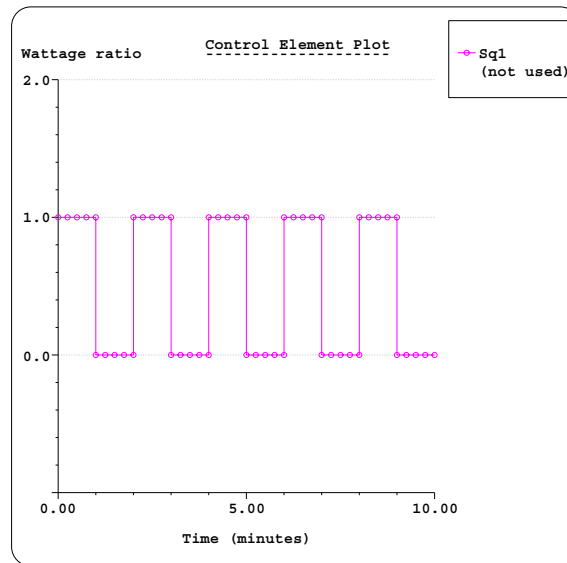

Figure 4: Control element graph

Control elements can be assigned to one or many nodes. After clearing the graph from the screen, assign the control element to the heat source:

**<F12 Root Menu> → Model → Control Elem → Assign → Time Base → Q vs Time → "Sq1"
→ Heat Source → All In Wind → USE**

To show that the control element has been assigned, Sauna changes to a "nightshade" symbol for the heat source node.

You can now calculate temperatures:

**<F12 Root Menu> → Analyze → Calc Temps → Duty Cycle → Optimized → Default
→ Natural → "25"**

The calculation takes longer than for a steady state calculation, but the total calculation time is still only a few seconds. When complete, you should see $T_{S1-junct} = 40.96^{\circ}\text{C}$ and $T_{S1-case} = 40.96^{\circ}\text{C}$. This is probably surprising, but remember that the square wave ends with an "off" period (see Figure 4 above).

To see the true variation of temperature, obtain a temperature vs. time graph:

**<F7 Info> → Temperature → Transient → Default → Lbl Nd Grp → All In Wind → USE
→ Minutes → Graph → Screen**

The graph will be as shown in Figure 5 on the next page:

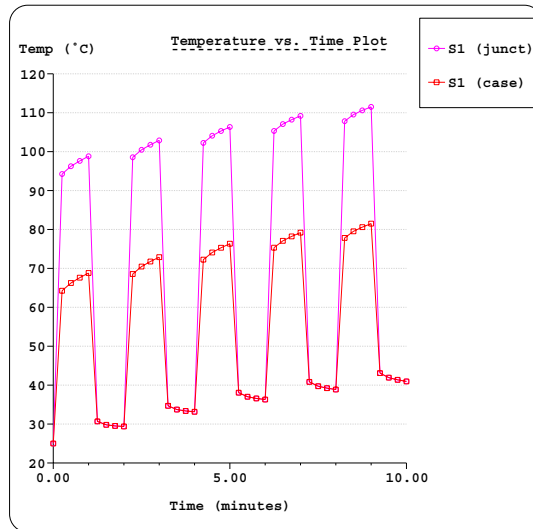

Figure 5: Temperature vs. time graph

This concludes a brief introduction to duty cycle transient. There are many more possibilities. Sauna supports temperature shutback and also random data duty cycles. In addition, a scripting language is provided, so you can define very complex wattage/time characteristics. **Sauna has duty cycle features not matched in other thermal simulation packages, regardless of price.**

After clearing the graph from the screen, delete the control element:

<F12 Root Menu> → Delete → Control Elem → Delete All → *click Yes button*

Creating a chip stackup

Now you will model the chip stackup problem shown in Figure 6:

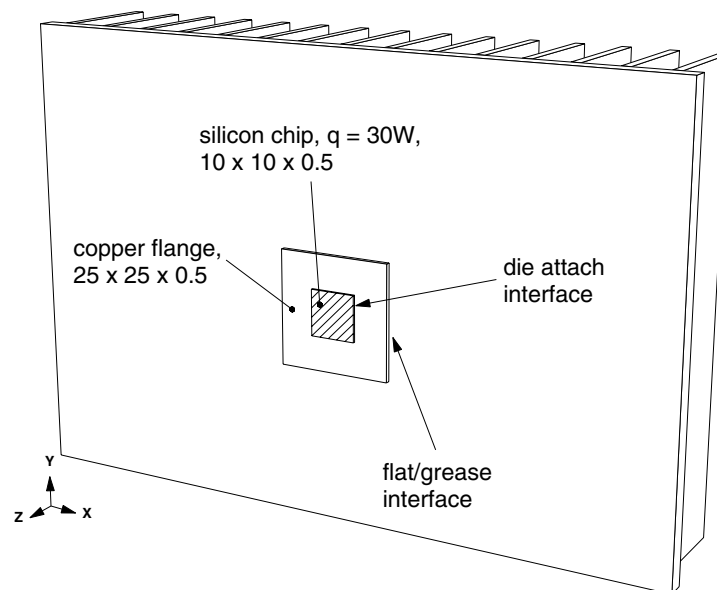

Figure 6: Chip stackup on heat sink

The chip stackup is located at the same position as the TO-220 power transistor. Begin by deleting the existing heat source:



<F12 Root Menu> → Delete → Node → Heat Source → Any Source → All In Wind → USE

Now create the copper flange and silicon chip assemblies:

**<F12 Root Menu> → Model → Assembly → Planar Plate → "Flange" → Rectangle → Vertical XY
→ "25,25,1" → Coords/Trap → "62.5,32.5,1" → Copper → Pure → Emis=0.1**

**Planar Plate → "Sil Chip" → Rectangle → Vertical XY → "10,10,.5" → Coords/Trap → "70,40,1.5"
→ Semi + Misc → Silicon → Emis=0.1**

As a quick visual check, switch to shade mode in a top view:

click  → **click** 

If something is wrong, use **Edit → Undo** and try again. Return to a front view:

click 

Modifying the silicon chip

Now you want to modify visibility so that only the silicon chip is visible. This is easy to do with “click surface” visibility:

**<F12 Root Menu> → Visibility → Isolate → Assembly → Assy Only → Click Surf
→ *click surface of silicon chip***

Turn off shade mode:

click 

You will see that the silicon chip has only one node. For any heat dissipating plate, there should be at least 4 nodes to achieve the best accuracy. Remesh the plate:

**<F12 Root Menu> → Edit → Assembly → Remesh/Align → Remesh → In Plane
→ Both Axes → Finer 4x → All In Wind → USE**

The silicon chip will be remeshed to have 4 nodes.

Next, you need to add the wattage to the silicon. Apply a “distributed” heat load:

<F12 Root Menu> → Model → Heat Input → Distribute → Any Assy → "30" → All In Wind → USE

You will see the message “Distributed wattage applied to 1 assembly” at the bottom of the screen. Also, note that the nodes are outlined in red to show that distributed wattage is present.

To make it easy to monitor junction temperature, add a label to the top-left node of the silicon chip:

**<F12 Root Menu> → Edit → Node → Labels → Trap 1 Node → Any Node → *click top-left node*
→ *enter "Tjunct" in text box* → *click OK button***

Stack joins and mesh alignment

Turn on all assemblies:

click 

Now you need to define a heat flow path from the silicon chip to the heat sink. This involves creating stack joins. When creating stack joins, the general rule is that nodes must be perfectly aligned in the plane of the assembly (there are a few exceptions). If you look at the screen, you will see that the nodes in the silicon chip do not line up with the nodes in the copper flange. And you have the same alignment problem between the copper flange and heat sink.

Fortunately, Sauna can usually align the nodes automatically. Sauna aligns the larger assembly to match the smaller assembly. It's done this way because the smaller assemblies are usually the heat generators. As a user, you just have to click "Yes" when Sauna asks if the nodes can be realigned.

Create the join between the silicon chip and the copper flange:

**<F12 Root Menu> → Model → Join → Stack → Ordinary → Strict → Die Attach → Trap 2 Assy
→ click edge of Flange → click edge of Sil Chip → click Yes button to accept realign**

Sauna will indicate that "Sil Chip, Flange successfully joined". Join the flange to the heat sink:

**Stack → Ordinary → Strict → Flat/Grease → Trap 2 Assy → click edge of Heat Sink
→ click edge of Flange → click Yes button to accept realign**

After joining, the model will appear as shown in Figure 7:

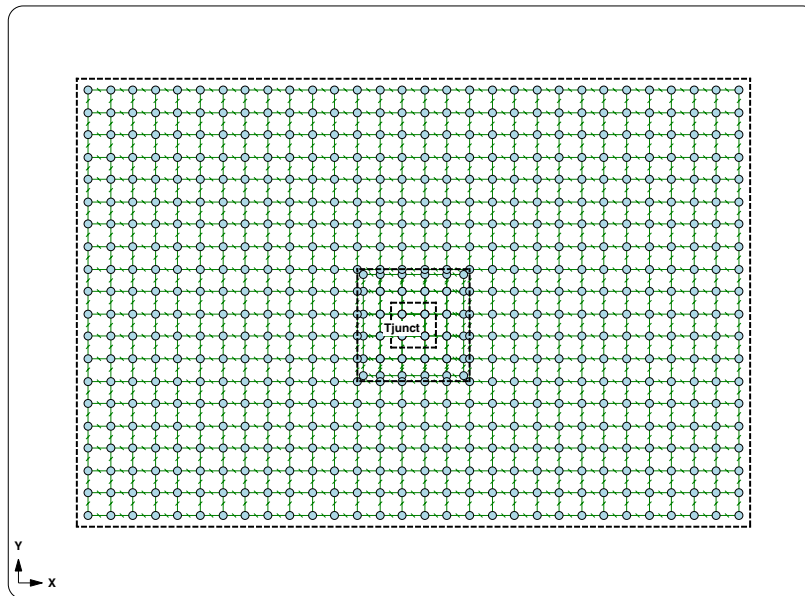

Figure 7: Model after creating stack joins

You are ready to calculate temperatures:

<F12 Root Menu> → Analyze → Calc Temps → Steady → Natural → "25"

You should obtain $T_{\text{junct}} = 93.11^{\circ}\text{C}$. This is lower than the temperature obtained for the TO-220 device. This is to be expected, the stackup is significantly larger.

Moving and copying the stackup

In the final section of the exercise, you will move the original chip stackup to the left. Then you will create a copy on the right side of the sink. The final geometry will be as shown in Figure 8. It will take about 5 minutes to complete the modification. If your available time is limited, feel free to skip the remainder of the exercise. Otherwise, please continue on.

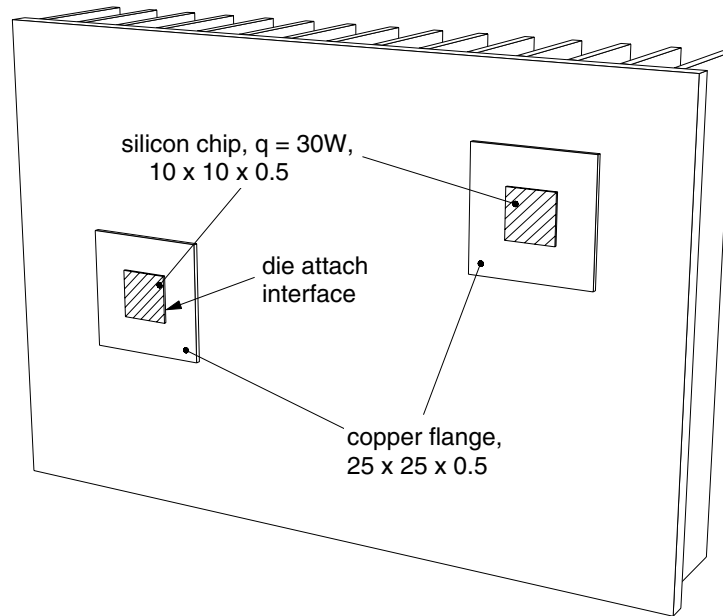

Figure 8: Heat sink with two chip stackups

To begin, you will move the stackup to the left by 42 mm. Moving is a three step process: (1) delete the join to the heat sink, (2) move the stackup and (3) rejoin to the heat sink.

Delete the flange-to-sink join with:

**<F12 Root Menu> → Delete → Join → Stack → Trap 2 Assy
→ click edge of Heat Sink → click edge of Flange**

Sauna will indicate that "1 join was deleted".

Move the stackup:

**<F12 Root Menu> → Move/Copy → Move → Assembly → Any Assy → Select 1
→ click edge of Flange → Select 1 → click edge of Sil Chip → USE → Dx → "-42"**

Join to the sink:

**<F12 Root Menu> → Model → Join → Stack → Ordinary → Strict → Flat/Grease → Trap 2 Assy
→ *click edge of Heat Sink* → *click edge of Flange* → *click Yes button to accept realign***

The nodes will be realigned and the stack join created.

Although you have not yet copied the stackup, calculate temperatures:

<F12 Root Menu> → Analyze → Calc Temps → Steady → Natural → "25"

You should obtain $T_{\text{junct}} = 96.24^{\circ}\text{C}$. The temperature increases because the stackup is no longer centered on the sink.

Copying the stackup

Now you will place a copy of the stackup on the upper-right of the heat sink ($\Delta X = 87$, $\Delta Y = 27$). Begin by making the copy:

**<F12 Root Menu> → Move/Copy → Copy → One → Assembly → Any Assy → Select 1
→ *click edge of Flange* → Select 1 → *click edge of Sil Chip* → USE
→ Dx-Dy-Dz → "87,27"**

The copy will be created. Normally, the next step is to join the 2nd stackup to the sink. However, there is a problem. Sauna can't align the heat sink to match both the left stackup and right stackup. Fortunately, there's a simple solution. You need to slice the heat sink. This will create independent meshes on the left and on the right.

Slice the heat sink at $X = 75$ mm:

**<F12 Root Menu> → Edit → Assembly → Subdivide → In Pln Slice → Line Slice
→ X-Coord → Enter Value → "75" → Select 1 → *click edge of Heat Sink* → USE**

With the slice, there will be two independent meshes of nodes and resistors. Now you can create a stack join for the right stackup. Make sure that you click on the right flange and the far-right edge of the heat sink. Make the join:

**<F12 Root Menu> → Model → Join → Stack → Ordinary → Strict → Flat/Grease → Trap 2 Assy
→ *click edge of right flange* → *click far-right edge of sink* → *click Yes button to accept realign***

Calculate temperatures:

<F12 Root Menu> → Analyze → Calc Temps → Steady → Natural → "25"

You should obtain $T_{\text{junct-left}} = 121.87^{\circ}\text{C}$ and $T_{\text{junct-right}} = 123.77^{\circ}\text{C}$.

This exercise is complete. You should delete the model:

<F12 Root Menu> → Delete → Everything → *click Yes button*

There are five other Sauna Quick Tours, as described on the following pages.

Sauna Quick Tour #2: Circuit Board Modeling

In the second Sauna Quick Tour, you will see how Sauna can be used for both quick models and detailed studies of circuit boards:

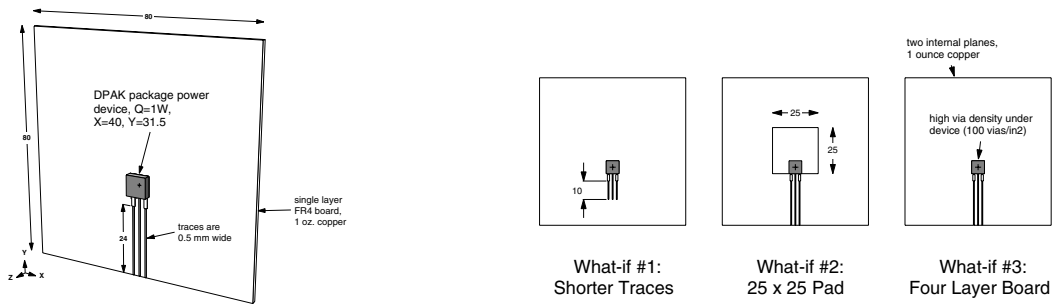

Simple DPAK device model

DPAK device what-ifs

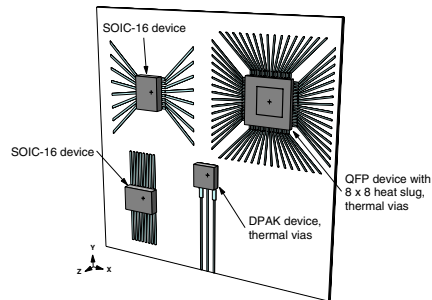

Four layer board with multiple components

Sauna Quick Tour #3: Basic Finned Box, Box With Board

With Sauna you can do a quick analysis of a box, or you can model in great detail (including internal convection and gray radiation analysis with automatic view factor calculation). These boxes are modeled:

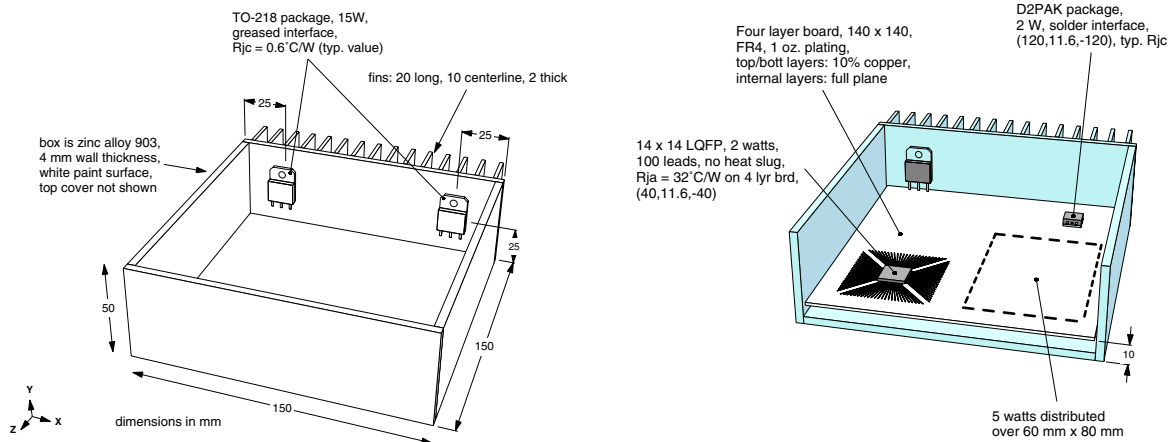

Basic finned box

Box with internal board

Sauna Quick Tour #4: Modeling LED Boards

You can model boards with both low power and high power LED's. Sauna's library includes 40 standard LED packages, covering a wide range of automotive, industrial and consumer lighting applications (user-defined packages are also allowed). It's easy to experiment with different pad sizes, add or remove internal copper planes, test different via densities and simulate boards which are bonded to heat sinks.

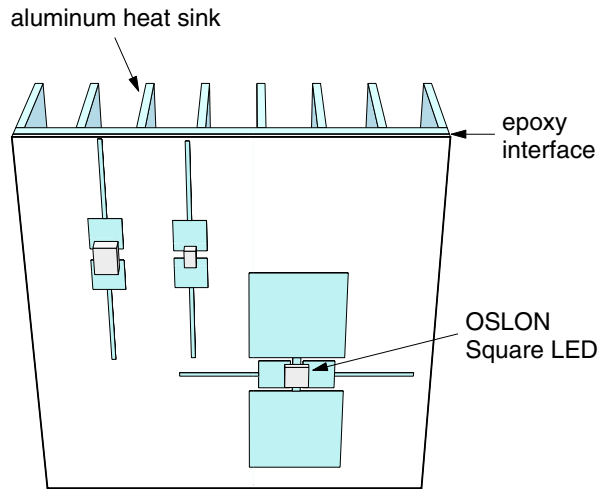
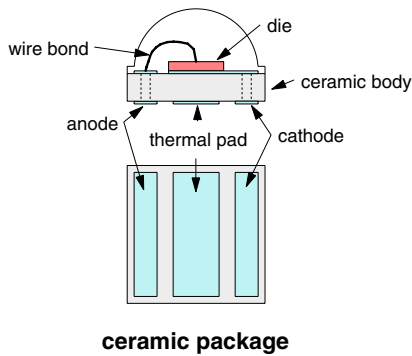
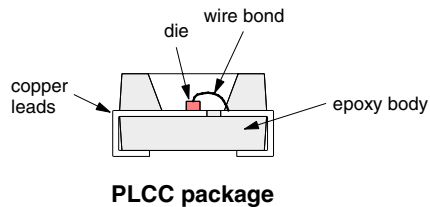

Multilayer board with high power LED, heat sink

Sauna Quick Tour #5: Tubes and Cold Plates

Sauna is not just for air cooling. You can also easily handle liquid cooling with water, anti-freeze mixtures, and more. In the fifth Sauna Quick Tour, you will start with a simple tube model. Then you will model a full cold plate, including heat sources.

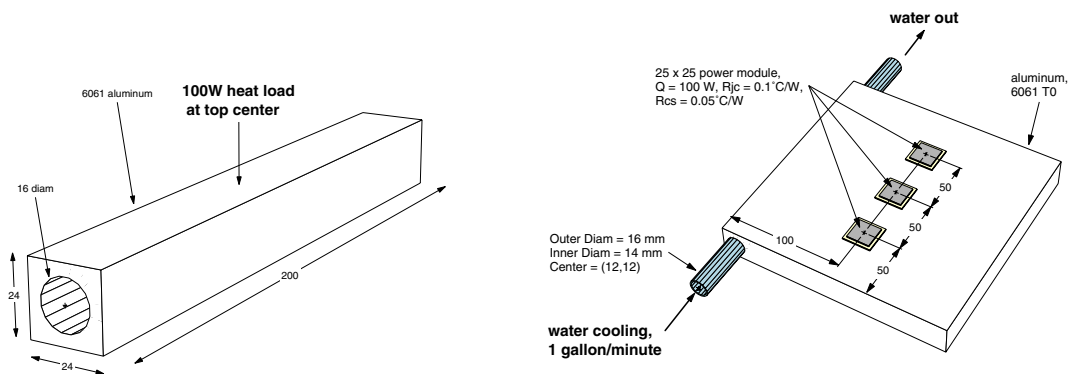

Tubes and cold plates with liquid cooling

Sauna Quick Tour #6: Exporting models to SPICE for electrical-thermal co-simulation

In this exercise you will export a Sauna model to the LTspice circuit simulation program. The LTspice program is an industry standard and is available as a free download. You will start with simple configurations and finish with the circuit below. When an LTspice circuit includes a Sauna model, there are surprising insights about circuit performance. *Thermal changes everything.*

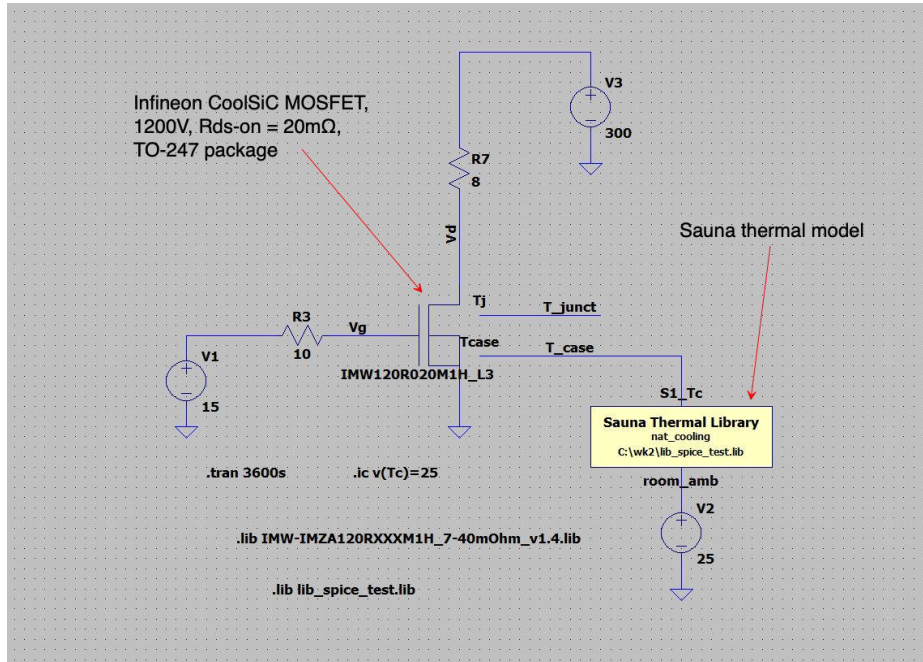

Co-simulation with Infineon CoolSiC MOSFET

Wrapping up and disclaimers

Thank you for working through Sauna Quick Tour #1. We hope you will work through the other Sauna Quick Tours.

Remember that the Sauna Quick Tours only provide an overview of Sauna's capabilities. **Important details have been omitted.** If you want to create accurate Sauna models, you must work through the Introductory Exercises in the Sauna User Manuals. Many of these exercises are also available online to prospective users (www.thermalsoftware.com/eval_exercises.htm). *You can even work through the exercises with the Sauna Evaluation Package.*

If you have questions, be sure to contact Technical Support (support@thermalsoftware.com, 734-761-1956). Please note that transient and duty cycle analysis is only available with the advanced version of the software: Sauna Modeling System. ♦